

# u\_floe

**all directions**  
OF SPACE



# all directions of space





**PL |** Tworząc kolekcję U\_FLOE zależało nam na podkreśleniu zmienności i dynamiki otaczającej nas natury. Inspiracją do powstania U\_FLOE były kry lodowe, które w zupełnie przypadkowy sposób tworzą ciekawe, harmonizujące ze sobą układy. Myśląc o kolekcji staraliśmy się połączyć pojedyncze elementy, które każdemu użytkownikowi zapewnią odrobinę intymności, ale jednocześnie będą spełniać założoną funkcję. Do tego dodaliśmy wysokie stoły i regały na rośliny, które doskonale uzupełniają przestrzeń tworząc ciepłą atmosferę oraz komfortowe i ergonomiczne miejsce pracy lub odpoczynku.

**DE |** Bei der Entwicklung der Kollektion U\_FLOE wollten wir die Variabilität und Dynamik der umgebenden Natur hervorheben. U\_FLOE wurde von Eisschollen inspiriert, die auf völlig zufällige Weise interessante Strukturen schaffen, die miteinander harmonieren. Als wir über die Kollektion nachdachten, haben wir versucht, einzelne Elemente zu kombinieren, die jedem Benutzer ein wenig Intimität geben, aber als Ganzes ihre geplante Funktion erfüllen. Dazu kamen hohe Tische und Pflanzenregale, die den Raum mit neuen Möglichkeiten ergänzen und den Charakter der nach der Philosophie von Biophilic Design gestalteten Räume widerspiegeln. So entsteht ein komfortabler, warmer und ergonomischer Raum.

**EN |** In creating the U\_FLOE collection, it was important to us to emphasize the changing dynamism of nature around us. The inspiration for U\_FLOE were ice floes – in completely random way, they creat interesting and harmonious arrangements. When conceiving the collection, we were trying to bring together individual elements that would provide each user with a little privacy, but which together would meet their designed purpose. We added high tables and shelves for plants, which complement the space with new possibilities and give the space a character in keeping with the philosophy of Biophilic Design. As a result, we can create a space that is comfortable, warm, and ergonomic.









**PL |** To co wyróżnia kolekcję U\_FLOE, to modułowość pozwalająca na tworzenie nieskończonych ilości układów o różnych kształtach i wymiarach.

**DE |** Was die U\_FLOE Kollektion auszeichnet, ist die Modularität, dank der man die unendlichen Kombinationen der Formen und Abmessungen gestalten kann.

**EN |** What distinguishes the U\_FLOE collection is its modularity that enables making an infinite number of arrangements with different shapes and dimensions

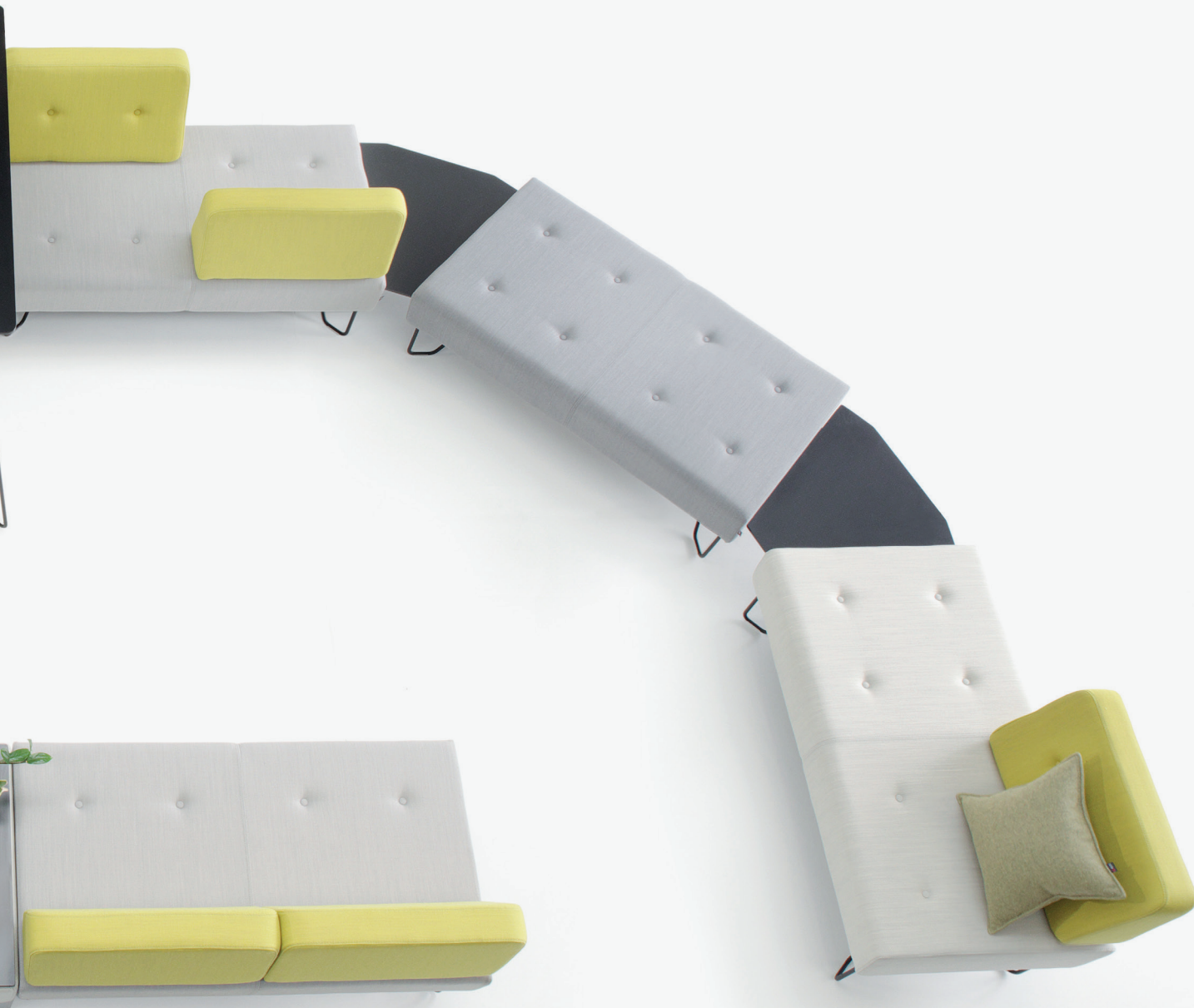

# BIOPHILIC DESIGN

## green is new black!

### PL | ROŚLINNOŚĆ STOSOWANA PRZEZ NASA

Istnieje kilka niezwykle odpornych roślin, które poradzą sobie w pomieszczeniach biurowych, gdzie zazwyczaj mamy niekorzystne dla roślin warunki rozwojowe. Najbardziej wytrzymałe w takim sztucznym środowisku są przede wszystkim Zamiokulkasy i wszelkie odmiany Sansevierii. W specjalnym badaniu NASA ustaliła listę roślin, które powinny się znaleźć w każdym biurze i domu, ze względu na ich zdolność do oczyszczania powietrza.

### DE | DIE VON DER NASA VERWENDETE VEGETATION:

Es gibt einige extrem widerstandsfähige Pflanzen, die in den Büroräumen, in denen normalerweise ungünstige Entwicklungsbedingungen für Pflanzen herrschen zurechtkommen. In solcher künstlichen Umgebung die meist haltbaren Pflanzengattungen sind in erster Linie die Zamioculcas und alle Sorten von Bogenhänfe (Sansevieria). In einer speziellen Untersuchung hat die NASA eine Liste von Pflanzen erstellt, die aufgrund ihrer Fähigkeit zur Luftreinigung in jedem Büro und Zuhause verwendet werden sollten.

### EN | FLORA USED BY NASA

There are some extremely resistant plants that will survive in any office space where usually there are no favourable development conditions for plants (artificial lighting, air-conditioning, central heating). The most resistant plants in such environment are Zamioculcas and all varieties of Sansaviera. NASA researchers set a list of the plants that make the best natural air filters in every household and office.

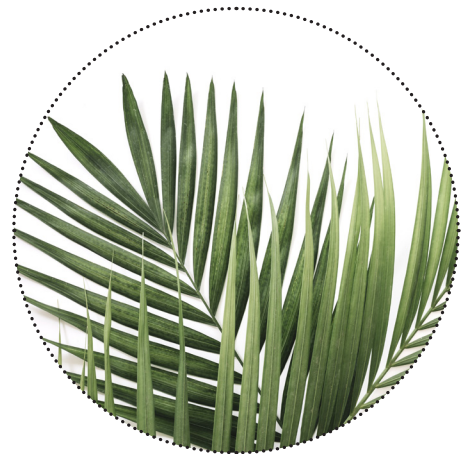







STEP OVER H



STEP OVER F

**PL |** Kolekcja została poszerzona z zachowaniem filozofii Biophilic Design. Biura wypełnione roślinami zbliżają nas do natury. U\_FLOE sugeruje nam ciekawe aranżacje roślinne, które znacznie wzbogacają całą kolekcję.

**DE |** Die Kollektion wurde in Übereinstimmung mit der Philosophie von Biophilic Design entwickelt. Ein Büro voller Blumen bringt uns der Natur näher. Deshalb ist U\_FLOE auch ein Vorschlag für eine interessante Präsentation von Pflanzen, die die Kollektion zusätzlich bereichern.

**EN |** The collection has been developed in the Biophilic Design philosophy. Offices filled with flowers bring us closer to nature. U\_FLOE is also a suggestion for a more interesting arrangement of plants, which further enrich the collection.



ST H



UF BOX + T



modern **METAL**...





UF\_SC\_12



UF\_SC\_D12





UF30110+STEP\_OVER\_L+UF\_TB180+UF2002



UF30110+UF\_BOX+T+UF2002



UF30110+UFP2BM+UF2000

**PL** | Przemysłana w każdym detalu, przeznaczona do wnętrz domowych, hal i poczekalni, stref chill i meeting point, restauracji i recepcji oraz przestrzeni publicznych.

**DE** | Bis ins kleinste Detail durchdacht, vorgesehen für Wohnräume, Hallen und Wartezimmer, Chill- und Meetingpoints, Restaurants und Empfangsbereiche sowie für öffentliche Räume.

**EN** | It is well thought-out in detail and designed for home interiors, lobbies, waiting rooms, chill zones, meeting points, restaurants, receptions and public spaces.

# little move big change



UF30110+UF\_TB180+UF2002



UF30110+UF\_BOX+T+UF2112R



UF30110+UFP2BM+UF2000+UF\_BOX+T





UF W 2211



UF W 31000 R

...or stylish **WOOD**?



UFW 32111 + UF SC D12



UFW 100



nogi dębowe  
Eichenbeine  
oak legs



nogi jesionowe  
Aschenbeine  
ash legs













UFW 100



UFW 2000



UFW 30000



UFW 101



UFW 2011



UFW 30110



UFW 31000 L



UFW 2100 R



UFW 121



UFW 2211



UFW 32111



UFW 111 R



UFW 2111 R



UFW 31110 R



UFTB



UF BOX + T



UF BOX



UF P

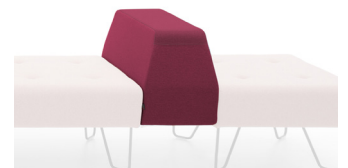

UF P2



UFW 120



UFW 2200

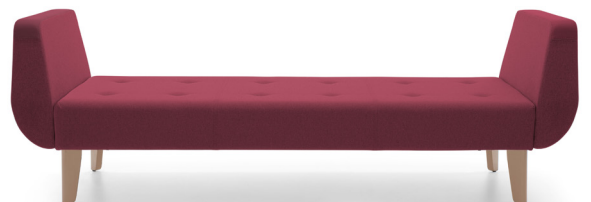

UFW 32000

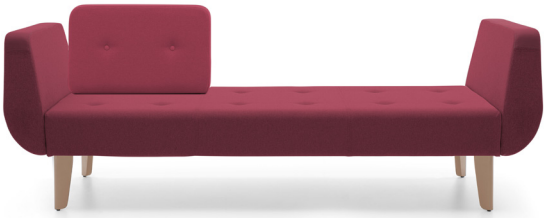

UFW 32100



UFW 32110

## clue\_space

**PL** | CLUE | (siedzenie do-społeczne) sprzyja budowaniu relacji międzyludzkich i komunikacji poprzez siedzenie twarzą w twarz.

**DE** | CLUE | (Zu-Sozialer Sitz) ist förderlich für den Aufbau von zwischenmenschlichen Beziehungen und Kommunikation durch das Sitzen von Angesicht zu Angesicht.

**EN** | CLUE | (social seating) - it helps to build interpersonal relations and communication by sitting face to face.



**PL** | Kolekcja U\_FLOE rozwija idee siedzenia do społecznego.  
**DE** | Die Kollektion U\_FLOE entwickelt die Idee des Sitzens zu sozialen.  
**EN** | U\_FLOE collection helps to expand the idea of social seating.

# construction\_of the index

**UF** **\_** **3** **1** **1** **2** **1** **R**

**PL** | BAZA  
**DE** | BASIN  
**EN** | BASE  
\_ – metal / Metall / metal  
W – drewno / Holz / wood

**PL** | LICZBA MIEJSC  
**DE** | ANZAHL DER PLÄTZE  
**EN** | NUMBER OF SEATS  
1 – jedno / Ein / one  
2 – dwa / Zwei / two  
3 – trzy / Drei / three

**PL** | LICZBA PODŁOKIETNIKÓW  
**DE** | ANZAHL DER ARMLEHNEN  
**EN** | NUMBER OF ARMRESTS  
0 – brak / keiner / none  
1 – jeden / Ein / one  
2 – dwa / Zwei / two

**PL** | POZYCJA OPARCÍ  
**DE** | POSITION  
DER RÜCKENLEHNEN  
**EN** | POSITION  
OF THE BACKRESTS  
0 – brak / keiner / none  
1 – przodem / Front / front  
2 – tyłem / rückwärts / back

**PL** | POZYCJA PODŁOKIETNIKA  
**DE** | POSITION DER ARMLEHNEN  
**EN** | POSITION OF ARMRESTS  
R – z prawej / auf der rechten Seite / on the right  
L – z lewej / auf der linken Seite / on the left



UF\_31121R



# drawings\_creation

**PL** | Przy tworzeniu układu konieczny jest rysunek poglądowy.

**DE** | Beim Erstellen des Layouts ist eine Bildzeichnung erforderlich.

**EN** | A pictorial drawing is required when creating the layout.

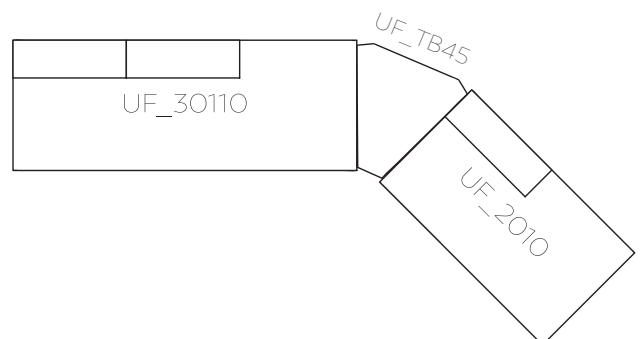
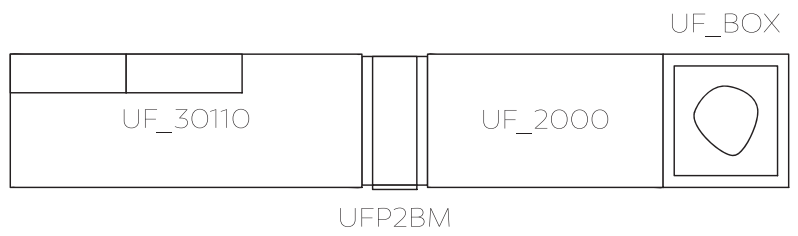
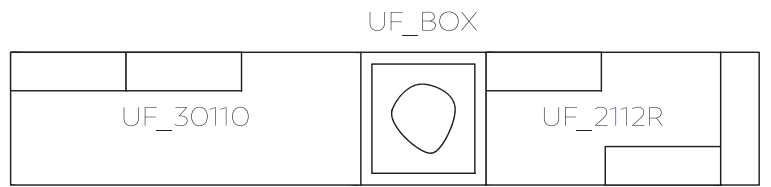
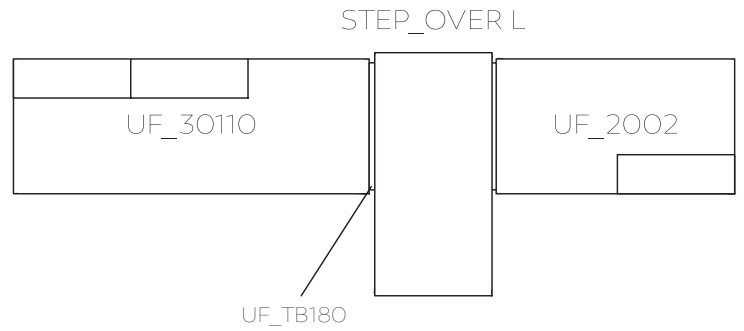

# modules\_sizes

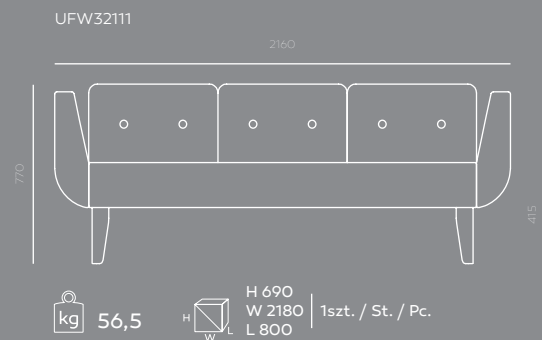
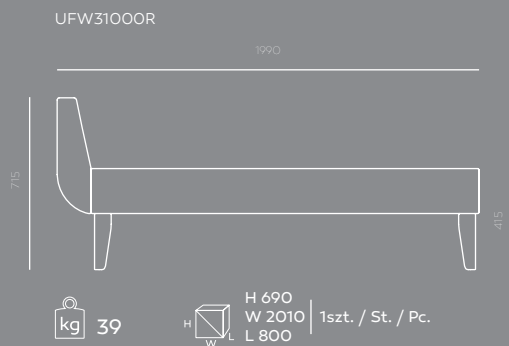
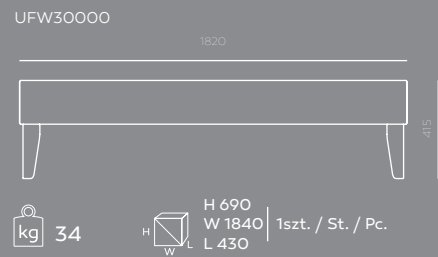
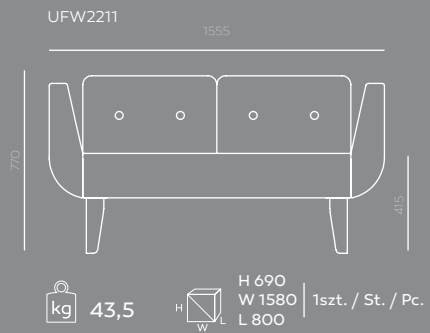
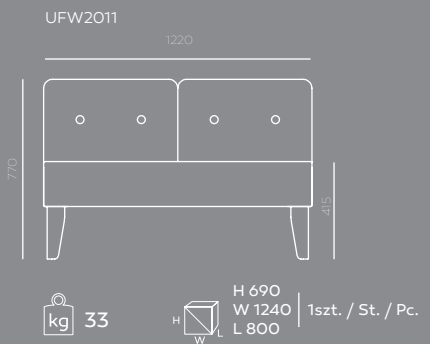
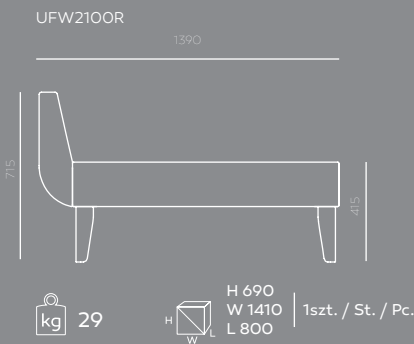
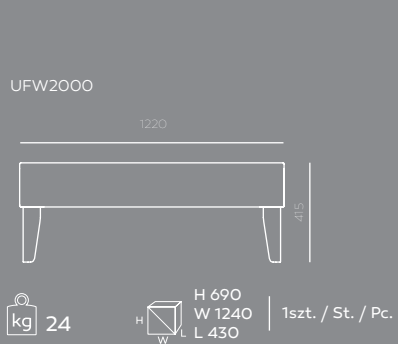
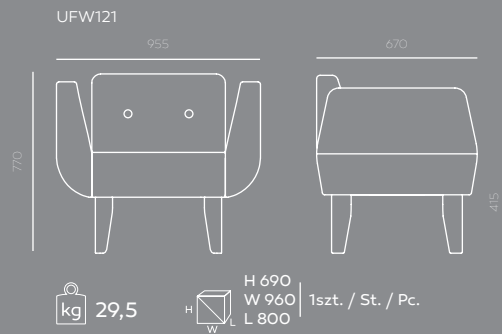
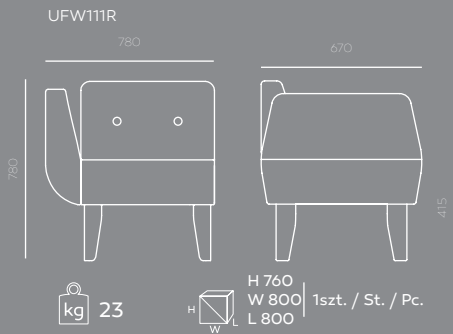
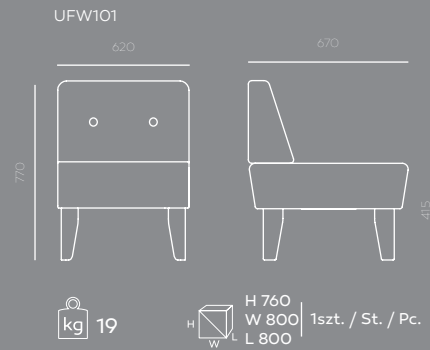
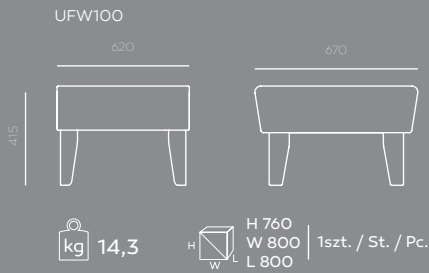

UF\_TB

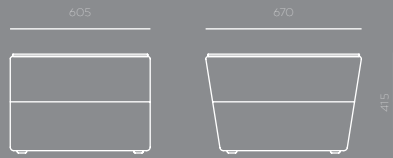

**kg** 17,6  H 760  
W 800  
L 800 | 1szt. / St. / Pc.

UF\_BOX + T

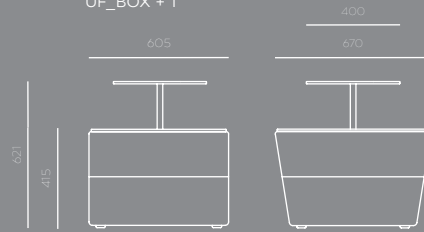

**kg** 18,7  H 760  
W 800  
L 800 | 1szt. / St. / Pc.

UFP2

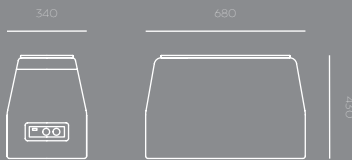

**kg** 11  H 770  
W 480  
L 700 | 1szt. / St. / Pc.

ST H

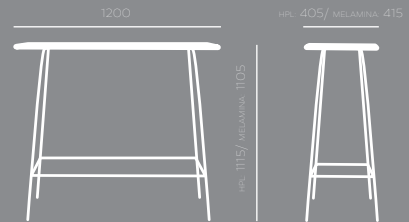

**kg** 15  HPL: H 1125  
W 1220  
L 425 | 1szt. / St. / Pc.  
MELAMINA: H 1135  
W 1220  
L 435 | 1szt. / St. / Pc.

STEP\_OVER\_L

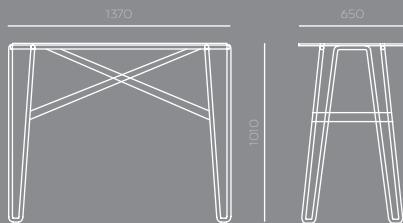

**kg** 24,3  H 1030  
W 620  
L 1264 | 1szt. / St. / Pc.

STEP\_OVER\_F

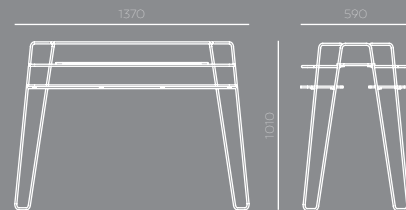

**kg** 28,3  H 1010  
W 655  
L 1218 | 1szt. / St. / Pc.

STEP\_OVER\_H

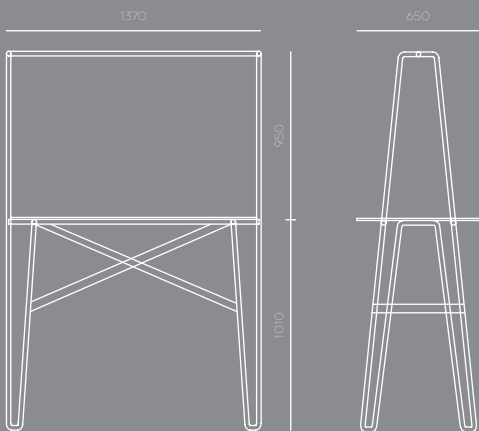

**kg** 30,5  H 1820  
W 620  
L 1264 | 1szt. / St. / Pc.

UF\_TB180

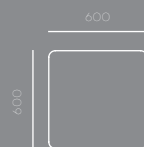

UF\_TB45

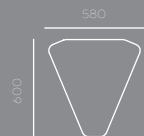

UF\_TB90



UF\_SC\_12

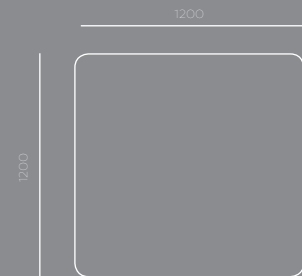

**kg** 18  H 50  
W 1220  
L 1220 | 1szt. / St. / Pc.

UF\_SC\_D12

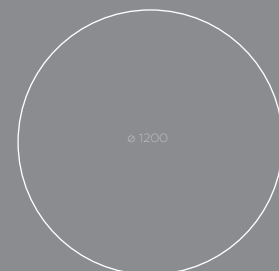

**kg** 12,5  H 50  
W 1220  
L 1220 | 1szt. / St. / Pc.



**5** Lat gwarancji  
Jahre Garantie / years guarantee



Good  
CHAIR  
BETTER  
**LIFE.**

Bejot sp. zo.o., ul. Wybickiego 2A, Manieczki, 63-112 Brodnica n.Poznań, POLAND  
Tel.: +48 (61) 281 22 25, fax: +48 (61) 281 22 54, e-mail: [biuro@bejot.eu](mailto:biuro@bejot.eu)

[www.bejot.eu](http://www.bejot.eu)  
edition: 1/2019

